

## SYSTEM LIMITATIONS

1. The maximum designed pressure listed herein shall be applicable to all roof pressure zones (i.e. field, perimeters, and corners). Neither rational analysis, nor extrapolation shall be permitted for enhanced fastening at enhanced pressure zones (i.e. perimeters, extended corners and corners).
2. All panels shall be permanently labeled with the manufacturer's name or logo, and the following statement: "Miami-Dade County Product Control Approved."
3. Panels shall be roll formed in continuous lengths from eave to ridge. Maximum lengths shall be as described in Miami-Dade County Roofing Application Protocol RAS 133.
4. All products listed herein shall have a quality assurance audit in accordance with the Florida Building Code and Rule 9B-72 of the Florida Administrative Code.
5. Panels may be jobsite roll formed with machine model #06010463 from JM Coils Association Inc.

## PROFILE DRAWINGS

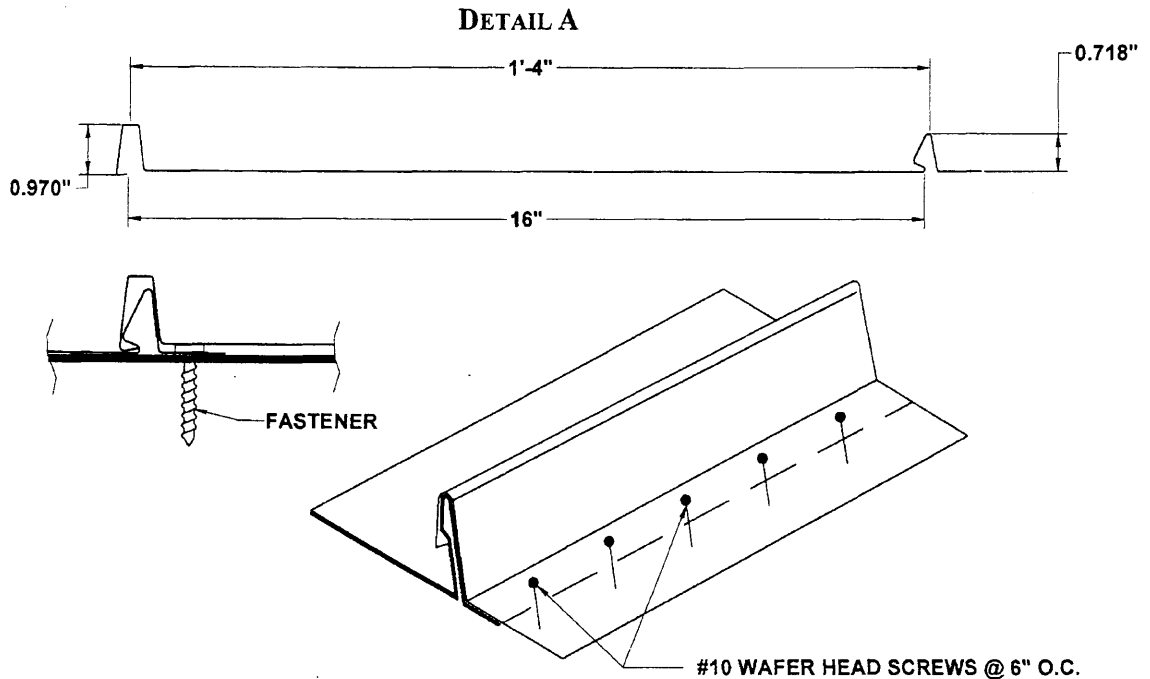

## "NAIL STRIP" METAL OR COPPER PLUS ROOF PANELS



NOA No.: 09-0121.14  
Expiration Date: 02/11/14  
Approval Date: 02/11/09  
Page 6 of 7

**DETAIL B**

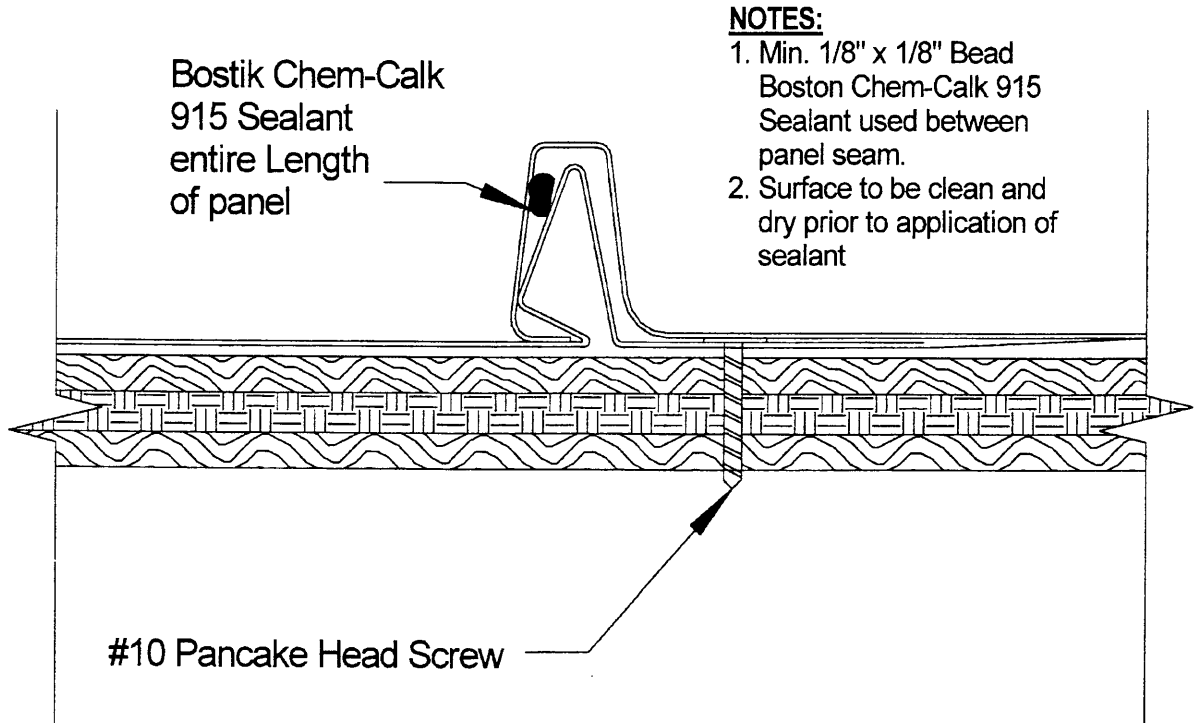

**END OF THIS ACCEPTANCE**



NOA No.: 09-0121.14  
Expiration Date: 02/11/14  
Approval Date: 02/11/09  
Page 7 of 7